

**SINGER**  
**246K14**

ILLUSTRATED  
LIST OF PARTS  
FOR  
No. 246K14 Machine



\*\*A Trade Mark of THE SINGER MANUFACTURING COMPANY

From the library of: Diamond Needle Corp

### INSTRUCTIONS FOR OILING

To ensure easy running and prevent unnecessary wear of the parts which are in movable contact, the machine requires oiling and when in continuous use, the oil gauge should be checked daily. The oil level should be maintained at the midpoint of the gauge.

To oil the machine, apply "TYPE A" OIL, sold only by Singer Sewing Machine Company, to the oil filler cup on top of the machine, as instructed in Form K6193.

## CONTENTS

	Page
Accessories ... ..	17
Belt Guard (Adjustable) ... ..	17
Blind Stitch Hemming Attachment (flip-up type) ... ..	17
Blind Stitch Hemming Attachment (yielding type) ... ..	18
Blind Stitch Hemming Attachment (latch type) ... ..	19
Chip Chute ... ..	19
Machine Base ... ..	20
Machine No. 216K14 ... ..	5
Numerical List of Parts ... ..	21
Set of Fittings, complete ... ..	16
Thread Unwinder... ..	20

From the library of: Diamond Needle Corp

# INSTRUCTIONS FOR ORDERING

In ordering from this List, the prefix and affix letters with the part number MUST BE quoted exactly as they are shown in the first column.

A number always indicates the same part in whatever List it may appear, or for whatever machine.

The affix letters (where shown) indicate the style of finish, as follows:—

- A. Hardened, Polished, Nickel Plated and Buffed.
- B. Polished, Nickel Plated and Buffed.
- C. Hardened only.
- D. Polished only.
- E. Soft, Not Polished.
- F. Hardened and Polished.
- G. Bright Rumbled and Nickel Plated.
- H. Blued.
- J. Nickel Plated only.
- K. Hardened and Nickel Plated.
- L. Brass Plated.
- M. Oxidized.
- R. Phosphate Coating Formed on Surface of Iron or Steel.
- S. Cadmium Plated.
- T. Copper Plated.
- U. Zinc Plated.
- V. Silver Plated.
- W. Polished and Nickel Plated.
- X. Black Oxide for Iron and Steel.
- Y. Black Nickel Plated only.
- Z. Chromium Plated.
- A.A. Buffed and Chromium Plated.
- A.B. Hardened, Polished, Buffed and Chromium Plated.
- A.E. Hardened, Bright Rumbled and Nickel Plated.
- A.F. Hardened, Bright Rumbled, Nickel Plated, Bright Rumbled and Chromium Plated.
- A.G. Alumilite (Plain).
- A.H. Alumilite (Dyed). Colour must be stated.
- A.J. Polished, Nickel Plated and Chromium Plated.
- A.K. Hardened, Polished, Nickel Plated and Chromium Plated.
- A.L. Heat Treated for Toughness.
- A.L.D. Heat Treated for Toughness and Polished.
- A.L.X. Heat Treated for Toughness and Black Oxide.
- A.S. Black Moulded Phenolic.
- A.T. Beige Moulded Phenolic.
- A.U. Brown Moulded Phenolic.
- A.W. Hardened then Flame Coated with Tungsten Carbide.
- B.A. Chrome Nickel, Satin Finish.
- B.B. Hardened and Chrome Nickel, Satin Finish.
- C.R. Hardened and Phosphate Coating Formed on Surface of Steel.
- C.U. Hardened and Zinc Plated.
- F.J. Hardened, Polished and Nickel Plated.
- T.A. Hardened, Polished, Copper and Nickel Plated and Buffed.
- T.B. Copper and Nickel Plated and Polished.
- T.J. Copper and Nickel Plated only.
- T.K. Hardened, Copper and Nickel Plated.
- T.L. Copper and Brass Plated.
- T.M. Copper Plated and Oxidized.
- X.C. Hardened and Black Oxide for Iron and Steel.
- Z.A. Hardened, Polished, Nickel Plated, Buffed and Chromium Plated.
- Z.B. Polished, Nickel Plated. Buffed and Chromium Plated.
- Z.C. Hardened and Chromium Plated.
- Z.D. Polished and Chromium Plated.
- Z.G. Bright Rumbled, Nickel Plated. Bright Rumbled and Chromium Plated.
- Z.J. Nickel and Chromium Plated.
- Z.T. Copper and Chromium Plated.

Parts marked with an asterisk (\*) are furnished only when the repairs are made at Factory.

## PARTS COMPLETE

FOR

## No. 246K14 MACHINE

For Trimming, Overedging and Blind Stitch Hemming or Welting Light and Medium Weight Fabrics. One Needle, One Looper, One Spreader. Two-Thread Overedge Stitch. Gathering Feed. Trimmer. Foot Lifter. Automatic Lubrication and Oil Cooling System.

No.	Plate	Name		
161347	2831	Chain Cutter ...	...	...
51362al	2831	" " Screw (2) ...	...	...
161001	24869	Chip Guard ...	...	...
1209j	24869	" " Screw (lower) ...	...	...
140509j	24869	" " " (upper) ...	...	...
164518	24877	Cloth Guide ...	...	...
160748	24877	" " Bracket ...	...	...
208j	24877	" " " Screw ...	...	...
140061k	24877	" " Hinge Screw ...	...	...
164519		Cloth Guide (swing-out) complete, Nos. 140061k, 160748 and 164518		
164513	24869	Cloth Plate ...	...	...
164512	24869	" " Extension ...	...	...
51408j	24869	" " " Screw ...	...	...
1700j	24869	" " " Nut ...	...	...
931084	24869	" " " " Lock Washer ...	...	...
161205	24869	" " Lock Spring ...	...	...
1700j	24869	" " " Nut ...	...	...
931084	24869	" " " " Lock Washer ...	...	...
1250al	24869	" " " Screw Stud ...	...	...
164104	24869	" " Plunger ...	...	...
164105	24869	" " " Spring ...	...	...
624al	24869	" " " Set Screw ...	...	...
164106	24869	" " Position Collar with two 624al ...	...	...
624al	24869	" " " " Set Screw ...	...	...
164514	24869	Cloth Plate with Extension, complete, Nos. 164205, 164512, 164513, two each 1700j, 51408j and 931084		
164003	24827	Feed Bar Hinge Pin (eccentric) ...	...	...
1389c	24827	" " " " Set Screw ...	...	...
164004	24827	" " Slide Block (back) ...	...	...
1628c	24827	" " " " ( " ) Nut ...	...	...
17022	24827	" " " " ( " ) " Washer ...	...	...

From the library of Diamond Needle Corp

No.	Plate	Name			
164005	24827	Feed Bar Slide Block (front)	...	...	...
164687	24827	" (back) Bar with 164010	...	...	...
164017	24827	" ( " ) " Connection	...	...	...
164008	24827	" ( " ) " " Bearing	...	...	...
164009	24827	" ( " ) " " Hinge Screw Stud	...	...	...
1671c	24827	" ( " ) " " " " " Nut	...	...	...
164010	24827	" ( " ) " " " " " Position Pin	...	...	...
164495	24873	" ( " ) Dog Section (left)	...	...	...
164243	24873	" ( " ) " " (right)	...	...	...
1100al	24873	" ( " ) " " ( " ) Screw	...	...	...
164496	24873	Feed (back) Dog, complete, Nos. 1100al, 164243 and 164495	...	...	...
1454f	24873	Feed (back) Dog Screw	...	...	...
164020	24827	" ( " ) Eccentric	...	...	...

NOTE.—Feed (back) Eccentric No. 164020 is furnished in 6 to 16, 18, 20, 22, 24, 28, 32 and 36 stitches to the inch, unless otherwise stated No. 164020 (14 stitches to the inch) is supplied regularly.

164006	24827	Feed (front) Bar with 164010	...	...	...
164007	24827	" ( " ) " Connection	...	...	...
164018	24827	" ( " ) " " Bearing	...	...	...
164009	24827	" ( " ) " " Hinge Screw Stud	...	...	...
1671c	24827	" ( " ) " " " " " Nut	...	...	...
164010	24827	" ( " ) " " " " " Position Pin	...	...	...
164208	—	Feed (back) and (front) Bars, complete, Nos. 164005 to 164008, 164017, 164018, 164687, two each 1671c, 164004 and 164009	...	...	...
164497	24873	Feed (front) Dog	...	...	...
1454f	24873	" ( " ) " Screw	...	...	...
164020	24827	" ( " ) Eccentric	...	...	...

NOTE.—Feed (front) Eccentric No. 164020 is furnished in 6 to 16, 18, 20, 22, 24, 28, 32 and 36 stitches to the inch, unless otherwise stated No. 164020 (14 stitches to the inch) is supplied regularly.

164520	24827	Feed Eccentric Cover	...	...	...
164705	<del>164300</del> 24827	" " " Bracket with 164023	...	...	...
157c	24827	" " " " Screw	...	...	...
629k	24827	" " " Hinge Screw...	...	...	...
164401	24827	" " " Latch Spring	...	...	...
227j	24827	" " " " " Screw	...	...	...
164023	24827	" " Oil Wick	...	...	...
164706	<del>164521</del> 24827	" " Cover, complete, for use with eccentrics of 4 stitches and above Nos. 629k, 164300, 164401, 164520 and two 164705 227j	...	...	...
164025	24812	Feed Lifting and Knife (movable) Eccentric...	...	...	...
164455	2831	Finger Guard	...	...	...
164456	2831	" " Adaptor	...	...	...
1259al	24829	" " " Screw	...	...	...
1423j	2831	" " " Screw	...	...	...
164704		Feed Eccentric Cover Bracket	...	...	...

No.	Plate	Name			
<del>550164026</del>	<del>2831</del>	Knife (movable) (2)	...	...	...
164027	2831	" ( " ) Clamp	...	...	...
140050c	2831	" ( " ) " Screw	...	...	...
164028	2831	" ( " ) Guard (lower)	...	...	...
164458	2831	" ( " ) " (upper)	...	...	...
164029	2831	" ( " ) Holder	...	...	...
198j	2831	" ( " ) " Screw	...	...	...
164030	2831	" ( " ) " " Bearing	...	...	...
164714	2831	" ( " ) Lever with 620al	...	...	...
164715	—	" ( " ) " 164714 with 132583, 164035, 164136 and 164153	...	...	...
164032	2831	" ( " ) " Bearing	...	...	...
447al	2831	" ( " ) " " Set Screw (long)	...	...	...
624al	2831	" ( " ) " " " " (short)	...	...	...
164373	24829	" ( " ) " Cover and Presser Bar (upright) Housing with 1259al	...	...	...
50073j	24829	" ( " ) " " " " " (upright) Housing with 1259al	...	...	...
164374	—	" ( " ) " Cover and Presser Bar (upright) Housing complete, Nos. 50060k, 164137 to 164139, 164142 to 164144, 164194 and 164373	...	...	...
164180	2831	Knife (movable) Lever Guide	...	...	...
164181	2831	" ( " ) " " Holder with two 110239al	...	...	...
164210	2831	" ( " ) " " " 164181 with 197j, 164177, 164180 and 164182	...	...	...
140239al	2831	" ( " ) " " " Set Screw	...	...	...
164182	2831	" ( " ) " " " Thread Tube	...	...	...
447al	2831	" ( " ) " " " Set Screw	...	...	...
197j	2831	" ( " ) " " " Screw	...	...	...
132583	2831	" ( " ) " Hinge Pin with 132584	...	...	...
132584	2831	" ( " ) " " " Oil Wick	...	...	...
620al	2831	" ( " ) " " " Set Screw	...	...	...
164034	2831	" ( " ) " " Stud	...	...	...
164035		" ( " ) " " " 164034 with 164036 and 164269	...	...	...
164036	2831	" ( " ) " " " Oil Wick (long)	...	...	...
164269	—	" ( " ) " " " " (short)	...	...	...
447al	2831	" ( " ) " " " Set Screw (back)	...	...	...
1143al	2831	" ( " ) " " " " (top)	...	...	...
164233	2831	" (stationary) (2)	...	...	...
164554	2831	" ( " ) Clamping Stud	...	...	...
164523	2831	" ( " ) " " Nut	...	...	...
164524	2831	" ( " ) Holder	...	...	...
164590	2831	" ( " ) " Adjusting Stud	...	...	...
190e	2831	" ( " ) " " Cap Screw	...	...	...
39541	2831	" ( " ) " " " Washer	...	...	...

From the library of the Diamond Needle Co.

No.	Plate	Name	No.	Plate	Name
164042	2831	Knife (stationary) Holder Sleeve ...	164207	24871	Machine Frame Bracket Key ...
140088c	2831	" ( " ) " " Screw ...	187c	24871	" " " " Screw ...
164043	2831	" ( " ) " Spring ...	140396e	24871	" " " " Screw (large) ...
164525	2831	" ( " ) " " Stud ...	164077	24871	" " " " " ( " ) Washer (fibre) ...
164462	2831	Lint Stripper with 735al ...	164229	24871	" " " " " ( " ) " (felt) ...
735al	2831	" " " Screw ...	140395c	24871	" " " " " (small) ...
164045	2830	Looper ...	164515	24813	" " " Cover (back) ...
164046	2830	" " Carrier with 460al, 50379f and 164202 ...	50571j	24813	" " " " ( " ) Screw (long) (2) ...
164660	2830	" " " Holder with 1083c, 140393al and 140596al ...	914j	24813	" " " " ( " ) " (short) ...
164661	-	" " " " 164660 with 1324c, 59456 and 164046 ...	164516	24813	" " " " ( " ) 164515 with 1637k and 140228c ...
1083c	2830	" " " " Clamping Screw ...	164081	24871	" " " Oil Lead ...
140596al	2830	" " " " Set Screw (left) ...	140088c	24871	" " " " " Screw ...
140393al	2830	" " " " " " (right) ...	1698j	24871	" " " " " Nut ...
1324c	2830	" " " " Screw ...	164082	24871	" " " " Plug Bracket ...
460al	2830	" " " " Set Screw ...	1036al	24871	" " " " " " Set Screw ...
59456	2830	" " " " Washer ...	164083	24871	" " " " " Screen ...
164048	2830	" " Driving Shaft ...	206j	24871	" " " " " Screw ...
164049	2830	" " " " Bushing (back) ...	<del>608-141083</del> <del>24871</del>		" " " " " Splash Guard (internal) ...
140394c	2830	" " " " " ( " ) Cap Screw ...	164605	24871	" " " " " " ( " ) Oil Pad ...
164293	2830	" " " " " ( " ) " " Washer (fibre) ...	164606	24871	" " " " " " ( " ) " " Fastener ...
164737	2830	" " " " " (front) ...	<del>609-141083</del> <del>24871</del>		Machine Frame Oil Splash Guard (internal) complete, Nos. 164605, 164605 and 164606 ...
164051	2830	" " " " Crank with 1083c ...	164085	24829	Machine Frame Oil Splash Guard (top) ...
1083c	2830	" " " " " Clamping Screw ...	51023w	24829	" " " " " " ( " ) Screw (2) ...
164052	24812	" " " " " Connection with two each 171al and 140159al ...	164722	24871	" " " " Tube with 164602 ...
164215	-	" " " " " 164051 with 164052 ...	147al	24871	" " " " " Set Screw ...
171al	24812	" " " " " Connection Cap (lower) Screw ...	164602	24871	" " " " " Wick ...
140159al	24812	" " " " " " " (upper) Screw ...	164089	24812	" " " Rotary Shaft ...
164067	2830	" " " " " Key ...	164090		" " " " " 164089 with 164097, 164215, 164216, 164217, two each 164093 and 164232 ...
1324c	2830	" " " " " " Screw ...	139026	24812	Machine Frame Rotary Shaft Ball Bearing ...
45057	2830	" " " " " " " Washer ...	164092	24812	" " " " " " " Housing ...
164053	2830	" " " " " Thrust Bearing ...	51369c	24812	" " " " " " " " Screw (3) ...
164739	2830	" " " " " Oil Ring (rubber) ...	164093	24812	" " " " " " " Sleeve (two pieces) ...
164740	2830	" " " " " " " Spacer ...	164232	24812	" " " " " " " Guide ...
50379f	2830	" " Set Screw ...	164600	24812	" " " " " " Bushing (front) ...
161202	2830	" " Stop Pin ...	1036al	24812	" " " " " " ( " ) Set Screw ...
164349	-	" " Thread Tube ...	164095	24812	" " " " " " (intermediate) ...
853al	24877	" " " " Set Screw ...	51332c	24812	" " " " " " ( " ) Set Screw ...
*164072	-	Machine Frame ...	164096	24812	" " " " " Counterbalance with 1036al ...
*164526	-	Machine Frame, complete, Nos. 140396e, 164072, 164077, 164528 and three 140395c ...	1036al	24812	" " " " " " Set Screw ...
164074	24813	Machine Frame Bottom Cover ...	164097	24812	" " " " " Key ...
164075	24813	" " " " " Gasket ...	51649c	24812	" " " " " Nut ...
914c	24813	" " " " " Screw (13) ...	131056	24812	" " " " " Washer ...
*164527	-	" " Bracket ...	164098	24812	" " " " " Oil and Ball Bearing Grease Retainer ...
*164528	-	" " " " 164527 with 164207 and two 187c ...			

No.	Plate	Name
164099	24812	Machine Frame Rotary Shaft Screw Stud ... ..
164100	24812	" " " " Thrust Bearing ... ..
164101	24872	" " Top Cover ... ..
164214	—	" " " " 164101 with 330j, 164103 and two 164118
164102	24872	" " " " Gasket ... ..
164103	24872	" " " " Oil Lead ... ..
330j	24872	" " " " " " Screw ... ..
51369j	24872	" " " " " " Screw (3) ... ..
164231	24812	" Pulley (round and "V" belt) with two H8a1 ... ..
164071	24812	" " Cap ... ..
140116x	24812	" " " " Screw ... ..
148a1	24812	" " " " Set Screw ... ..
164109	24829	Needle Clamp ... ..
51720c	24829	" Clamping Nut ... ..
164110	24829	" Driving Shaft with 164118 ... ..
164275	—	" " " " 164110 with 51720c, 164109 and 164117 ... ..
164111	24829	" " " " Bushing ... ..
161112	24829	" " " " Cap ... ..
164113	24829	" " " " Oil Lead ... ..
452a1	24829	" " " " " " Hole Plug Screw ... ..
164114	24829	" " " " Crank with 1083c and two 140596a1 ... ..
164115	24829	" " " " Ball ... ..
1083c	2830	" " " " Clamping Screw ... ..
164217	24812	" " " " Connection with 164115 ... ..
157a1	24812	" " " " " Cap (lower) Screw (2) ... ..
171a1	24812	" " " " " " (upper) Screw (2) ... ..
140596a1	24829	" " " " Set Screw ... ..
164117	24829	" Holder ... ..
164118	24829	" Stop Pin ... ..
164119	24812	Oil Agitator ... ..
164120	24871	" Cooler with two 164125 ... ..
164121	24871	" " Cover ... ..
164123	24871	" " " " 164121 with 164135 ... ..
164122	24871	" " " " Gasket ... ..
145j	24871	" " " " Screw ... ..
164124	24871	" " Gasket ... ..
164125	24871	" " Oil Pipe ... ..
164126	24871	" " " " Tube with 138269 and 164128 ... ..
164127	24871	" " " " Coupling ... ..
51630	24871	" " " " Lock Nut ... ..
138269	24871	" " " " Sleeve ... ..
164128	24871	" " " " Wick ... ..
51139j	24871	" " Screw (long) (2) ... ..
1324j	24871	" " " " (short) ... ..
164135	24871	" Cup for filling machine ... ..

151X5

Needle, size 11

No.	Plate	Name
164607	2831	Oil Deflector ... ..
164131	24874	" Sight Gauge Background Disc ... ..
164132	24871	" " " " " " Gasket ... ..
164133	24871	" " " " Window ... ..
164132	24871	" " " " " " Gasket ... ..
164134	24871	" " " " " " Retainer ... ..
164132	24871	" " " " " " Gasket ... ..
1485j	24871	" " " " " " Screw (2) ... ..
164136	2831	Presser Bar Bracket ... ..
164137	24829	" " Lifting Bracket with 462a1, 624a1 and 51846 ... ..
51846	24829	" " " " " " Roller and Stud ... ..
624a1	24829	" " " " " " Set Screw (long) ... ..
462a1	24829	" " " " " " " " (short) ... ..
164138	24829	" " " " Lever ... ..
164139	24829	" " " " " " Spring ... ..
140228c	24813	" " " " " " Stop Screw ... ..
1637k	24813	" " " " " " Nut ... ..
164350	2831	" " (swing-out) ... ..
164141	2831	" " ( " ) Lifting Screw Stud ... ..
1700j	2831	" " ( " ) " " Nut ... ..
164142	24829	" " ( " ) Opening Lever ... ..
50060k	24829	" " ( " ) " " Hinge Screw ... ..
140510c	2831	" " ( " ) Pivot Screw ... ..
164351	2831	" " ( " ) " " Lock Washer ... ..
51362a1	2831	" " ( " ) " " " " Screw ... ..
164143	24829	" " (upright) ... ..
164144	24829	" " ( " ) Spring ... ..
164146	—	" " ( " ) " (heavy) ... ..
NOTE: No. 161111 is supplied with machine.		
*164352	—	Presser Foot Body (back) ... ..
*164508	—	" " " " (front) ... ..
164509	24873	" " " " (hinged) Nos. 164352, 164355 and 164508 ... ..
164355	—	" " " " Hinge Pin ... ..
164356	24873	" " " " Chaining-off Finger ... ..
164147	24873	" " Clamping Plate ... ..
50225j	24873	" " " " Screw ... ..
164511	24873	Presser Foot (hinged) complete, Nos. 164147, 164356, 164509, 164510 and two 50225j ... ..
164517	24871	Presser Foot Hemming Guide for $\frac{1}{4}$ in., $\frac{3}{8}$ in., $\frac{1}{2}$ in., $\frac{5}{8}$ in., $\frac{3}{4}$ in., $\frac{7}{8}$ in., 1 in., $1\frac{1}{4}$ in., $1\frac{3}{4}$ in., and $1\frac{1}{2}$ in. gauges ... ..
NOTE: When ordering No. 164517 gauge required must be stated. Unless otherwise specified No. 164517 will be furnished in $\frac{3}{4}$ in. gauge.		
164510	24873	Presser Foot Hemming Guide Clamping Washer ... ..
164194	24829	Pressure Regulating Thumb Screw ... ..
164252	2830	Spreader ... ..
164056	2830	" Carrier with 50370e ... ..

From the library of: Harmond Needle Corp







## ACCESSORIES

No.	Plate	Name
164203	2760	Feed Eccentric Extractor (not regularly furnished with machine)
164592	2760	Gauge (not regularly furnished with machine)
151 x 5		Needles, size 11 (6)
120342	2760	Oiler
164198	2760	Presser Bar Lifting Chain Spring (under table)
85318	2760	Screw Driver
164196	2760	Threader (6)
		Tin of Oil, Grade "A" (1 Pint)
164204	2760	Tweezers
164197	2760	Wrench (socket)
8909	2760	" (flat)

## BELT GUARD (adjustable)

No.	Plate	Name
164183	24866	Belt Guard
164199	24866	" " Bracket (back)
164200	24866	" " " (front)
51326j	24866	" " Screw
164201	24866	Belt Guard (adjustable) complete, Nos. 164183, 164199, 164200, two each 51326j and wood screws $\frac{3}{4}$ in. No. 7 F.H.

## Blind Stitch Hemming Attachment (flip-up type)

## Complete, No. 160381 For General Work

No.	Plate	Name
160376	24877	Folder
160377	24877	" Hinge
160378	24877	" " Bracket with 904al
59480	24877	" " Pin
904al	24877	" " " Set Screw
160574		Folder Holder, complete, Nos. 335j, 1628K, 59480, 160377, 160378, 160379 and 160380
160379	24877	Folder Screw Stud
1628k	24877	" " " Nut
160380	24877	" Stop Plate
335j	24877	" " " Screw
160381	24877	Blind Stitch Hemming Attachment, complete, Nos. 160376 and 160574

## Blind Stitch Hemming Attachment (yielding type)

## Complete, No. 160384 For Tubular Work

No.	Plate	Name
160385	24877	Folder
160383	24877	" Bracket
160575		Folder Holder, complete, Nos. 3146, 50388j and 160383
50388j	24877	Folder Screw
3146	24877	" " Washer
160384	24877	Blind Stitch Hemming Attachment, complete, Nos. 160385 and 160575

## Blind Stitch Hemming Attachment (latch type)

## Complete, No. 160392 For Open End Work

No.	Plate	Name
160382	2849	Folder
160386	2849	" Hinge
160387	2849	" " Bracket with 468c
59480	2849	" " Pin
468c	2849	" " " Set Screw
160388	2849	" " Plunger
160389	2849	" " " Spring
160576		Folder Holder, complete, Nos. 202j, 973j, 1772c, 3146, 50388j, 59480, 160386, 160387, 160388, 160390, 160391 and three 160389
160390	2849	Folder Latch
160391	2849	" " Guide Bracket
202j	2849	" " " " Screw
973j	2849	" " Hinge Screw
1772c	2849	" " " " Nut
160389	2849	" " " Spring (2)
50388j	2849	" Screw
3146	2849	" " Washer
160392	2849	Blind Stitch Hemming Attachment, complete, Nos. 160382 and 160576

## Blind Stitch Hemming Attachment Support, complete

No.	Plate	Name
164234	24877	Adjusting Slide (cylindrical) ... ..
164235	24877	Hinge Bracket ... ..
140458c	24877	" " Thumb Screw ... ..
164236	24877	Support ... ..
140456c	24877	" Adjusting Thumb Screw ... ..
140457j	24877	" " " Locking Screw ... ..
164238	24877	" Cap ... ..
164237	24877	Blind Stitch Hemming Attachment Support, complete, Nos. 140456k, 140457j, 140458c, 164234 to 164236 and 164238 ...

## CHIP CHUTE

(supplied only when specified on order)

No.	Plate	Name
168198	24866	Chip Chute with four wood screws $\frac{3}{8}$ in. No. 6 R.H. blacked ...

## FOOT LIFTER PARTS

No.	Plate	Name
6439	24866	Chain, 36 in. to 45 in. with 56864 and 56865 ... ..

NOTE.—When ordering No. 6439, give length required.

4879	24866	Chain Connecting Link ... ..
56864	24866	" Hook (large) ... ..
56865	24866	" " (small) ... ..
4881	24866	Treadle ... ..
4882	24866	" Shaft ... ..
4883	—	" Spring ... ..
4884	24866	" Stand ... ..
4885	24866	Treadle, complete, Nos. 4879, 4881 to 4884 and two wood screws 1 in. No. 16 F.H. ... ..

NOTE.—The stands recommended for machines of Class 216K include a suitable treadle. If machine is fitted on a stand or other equipment which does not include a foot lifter treadle, orders should state that No. 4885 is to be supplied and it will be furnished without extra charge.

## MACHINE BASE

No.	Plate	Name
164184	24866	Machine Base with two each wood screws $\frac{3}{8}$ in. No. 8 R.H. and 1 $\frac{1}{2}$ in. No. 6 F.H. ... ..
164188	24866	Machine Cushion (large) (2) ... ..
164189	24866	" " (small) (2) ... ..
164190	24866	" Pad (felt) ... ..
140418c	24812	" Screw Stud (back) ... ..
657c	24812	" " " (front) ... ..

## THREAD UNWINDER No. 151031

## For Three Spools

No.	Plate	Name
228692	—	Spool Pin ... ..
201528x	—	" " Nut ... ..
359243	—	" " Washer ... ..
151023	24764	" Rest with 858al, three each 201528x, 228692 and 359243 ... ..
150203	24764	" " Cushion (felt) ... ..
858al	24764	" " Hub Set Screw ... ..
151024	24764	" " Rod ... ..
1122c	24764	" " " Set Screw ... ..
151025	24764	" " Stand with two 1122c and three wood screws 1 in. No. 12 F.H. ... ..
151026	24764	Thread Guide (lower) ... ..
50311c	24764	" " ( " ) Holder Set Screw ... ..
151027	24764	" " ( " ) Support with 50311c ... ..
151028	24764	" " (upper) ... ..
151029	24764	" " ( " ) Holder with four 453al ... ..
151030	24764	" " Rod ... ..
453al	24764	" " " Set Screw ... ..
453al	24764	" " " Set Screw (3) ... ..
151031	24764	Thread Unwinder, complete, Nos. 151023 to 151027, 151029, 151030, two 151028 and three 150203 ... ..

85318

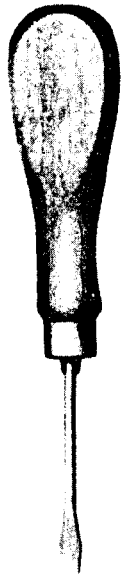

164197



8909



164196 164198



120342

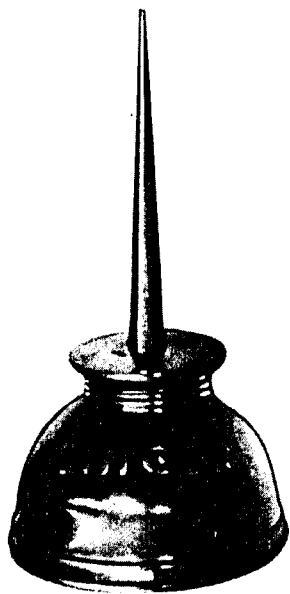

164592



164204



164203

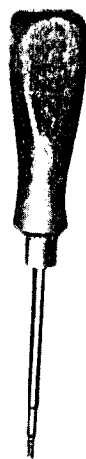

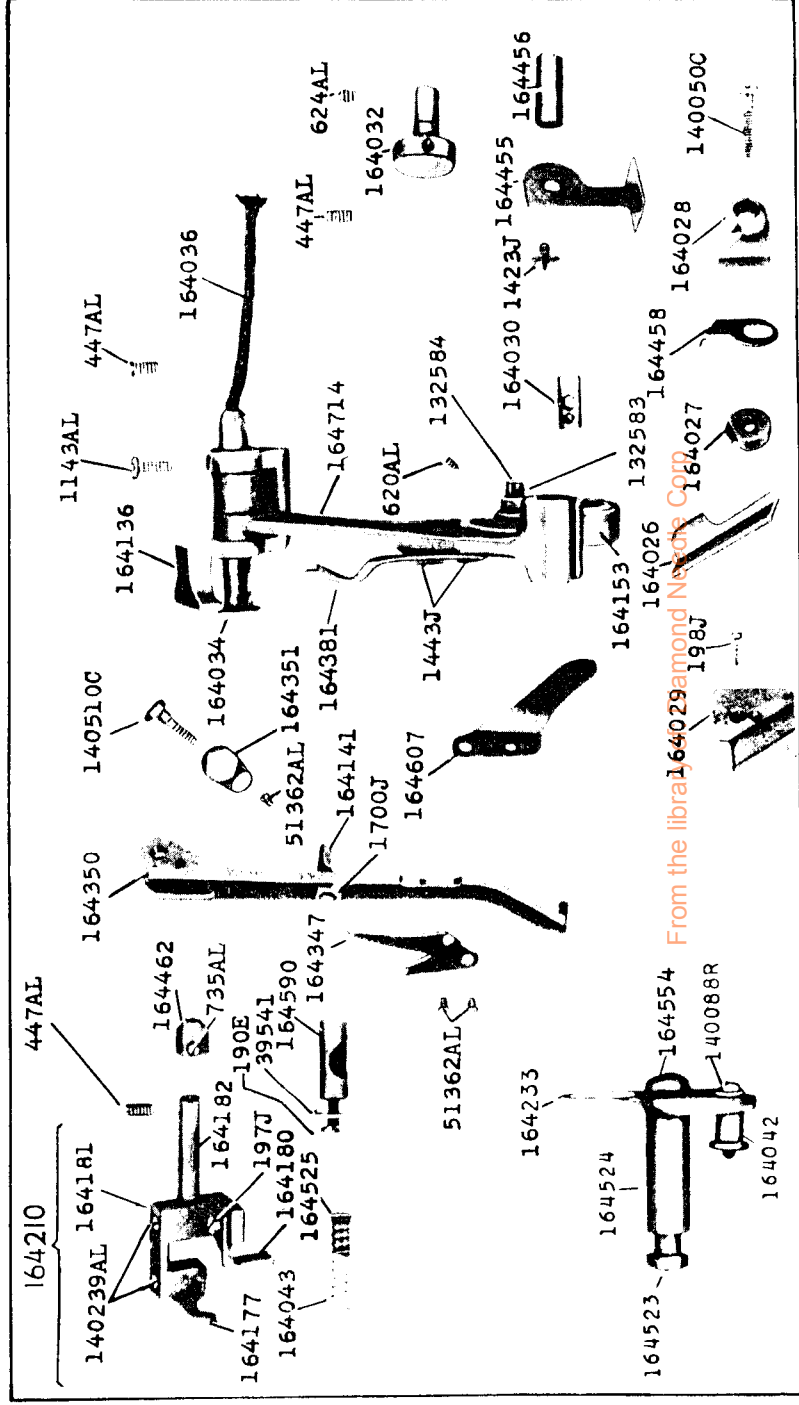
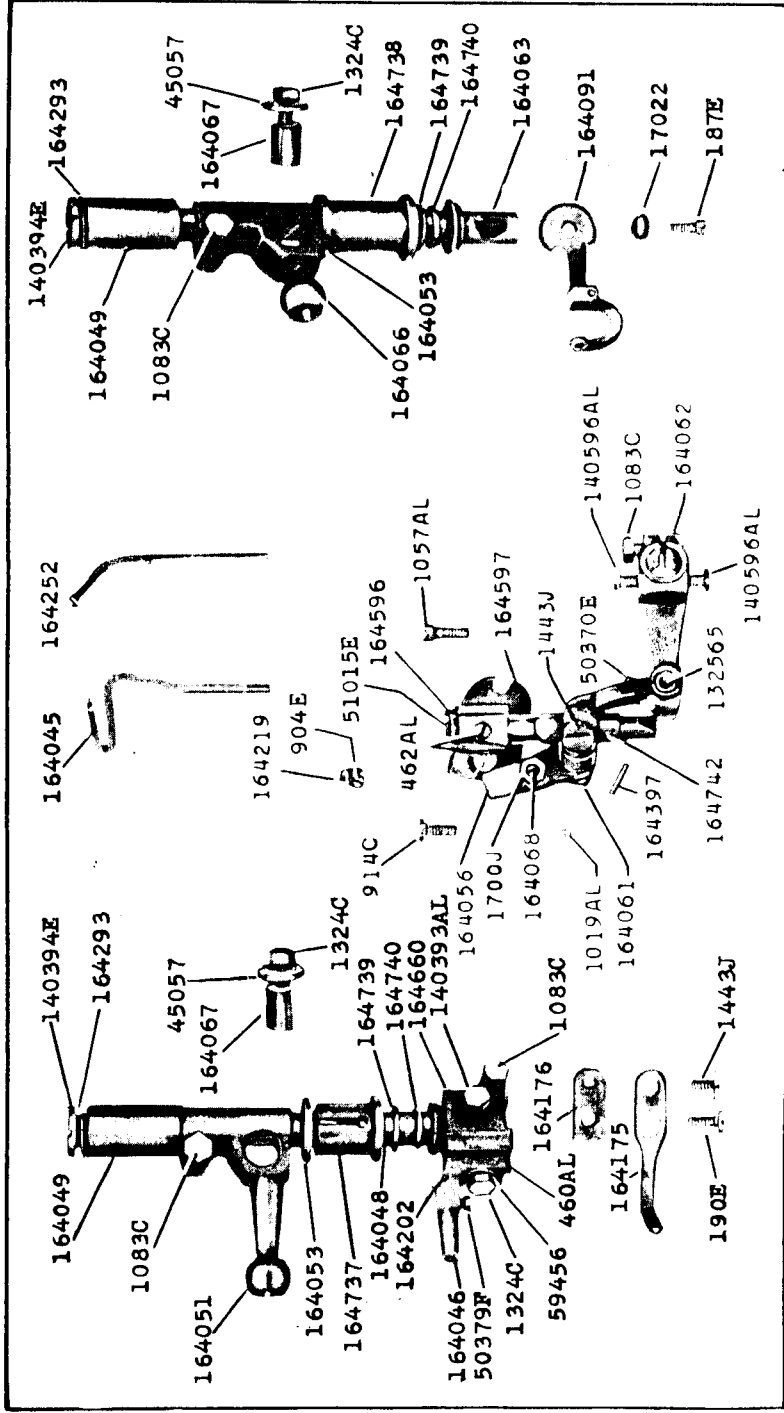

From the library 164029 at the National Archives

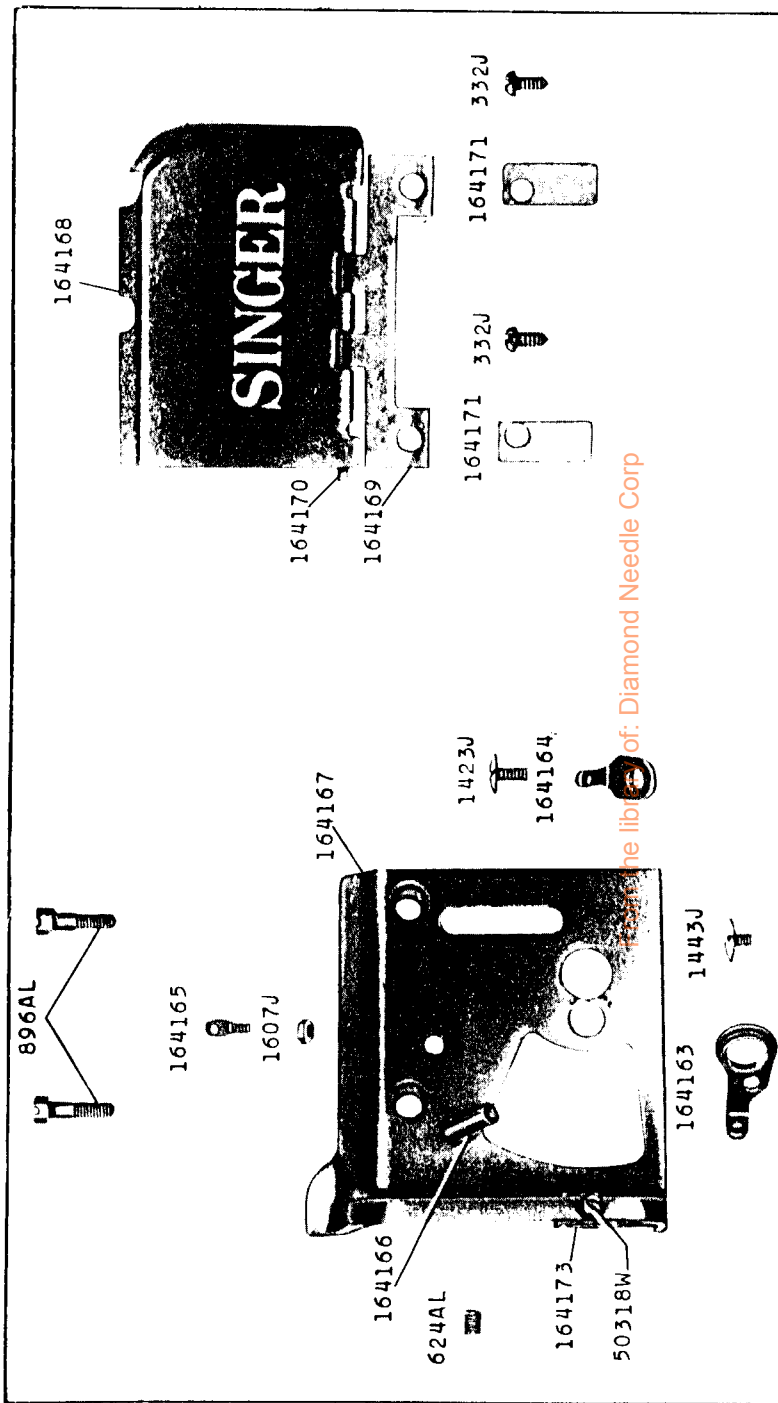
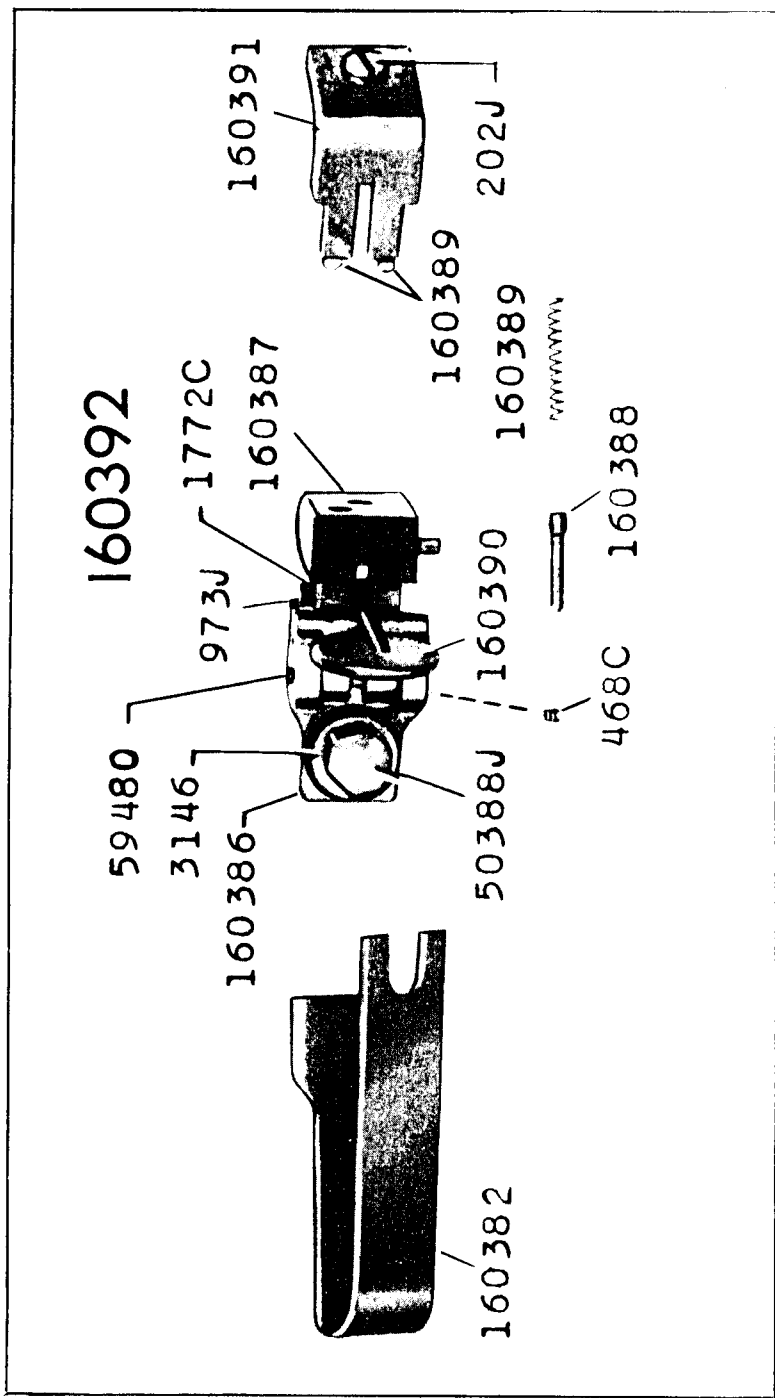

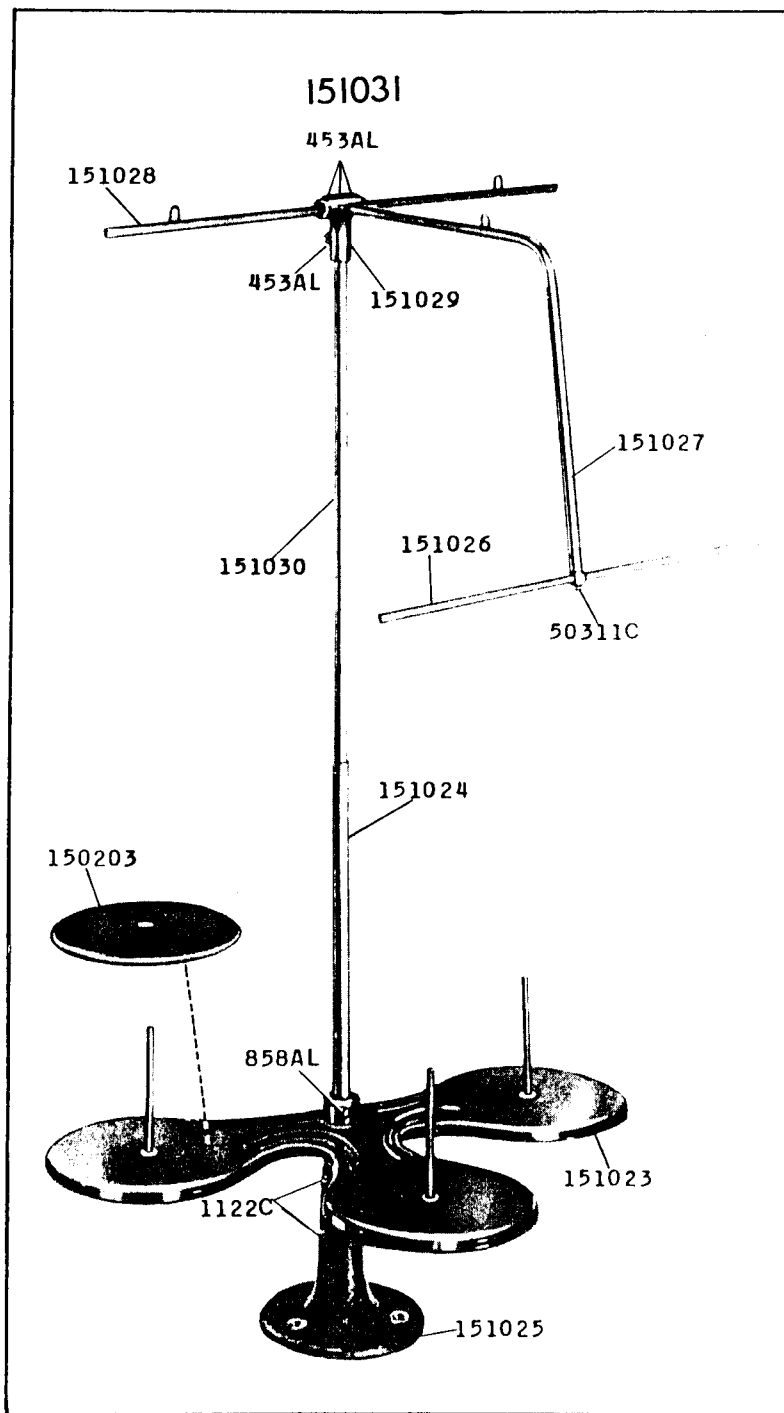







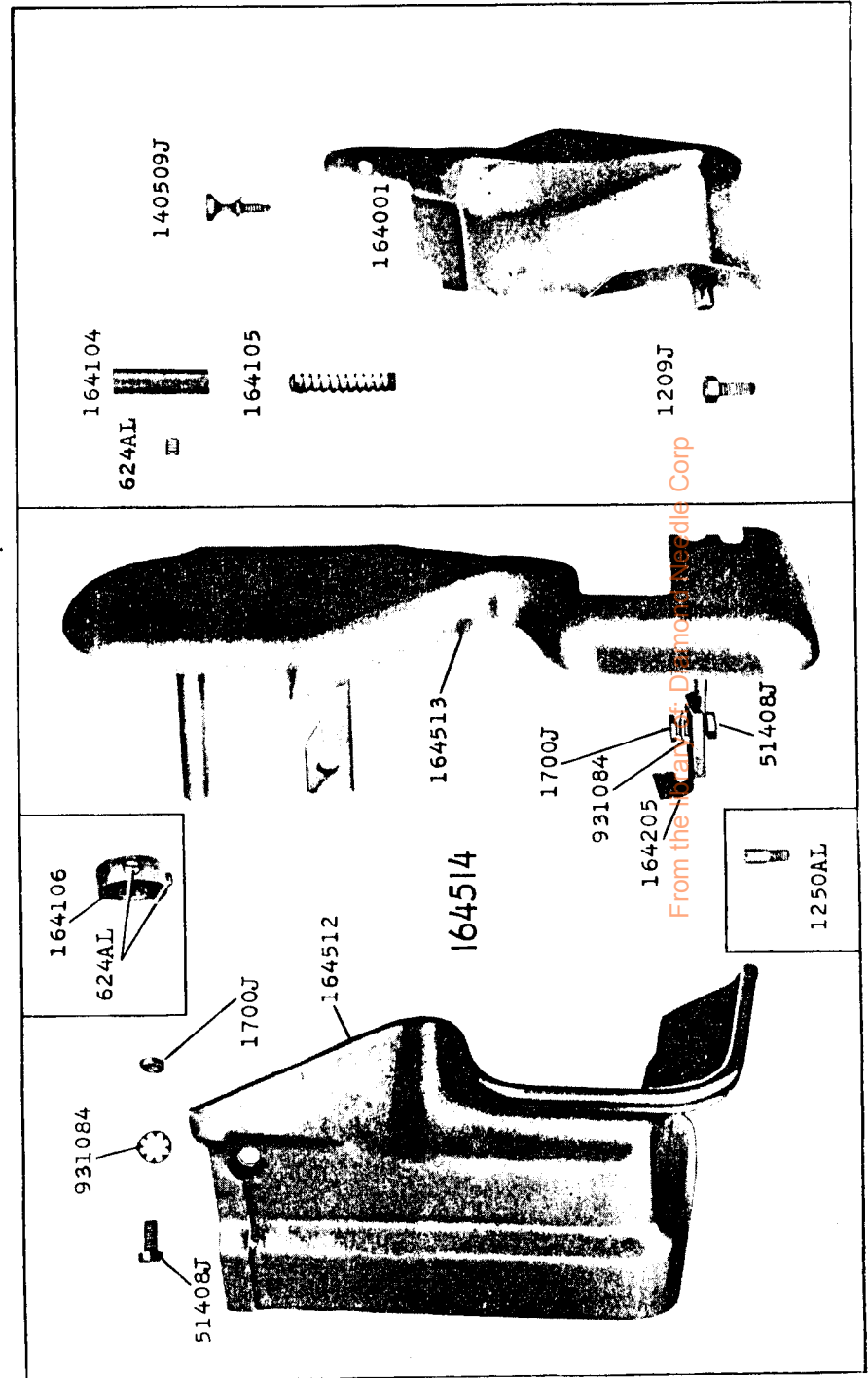
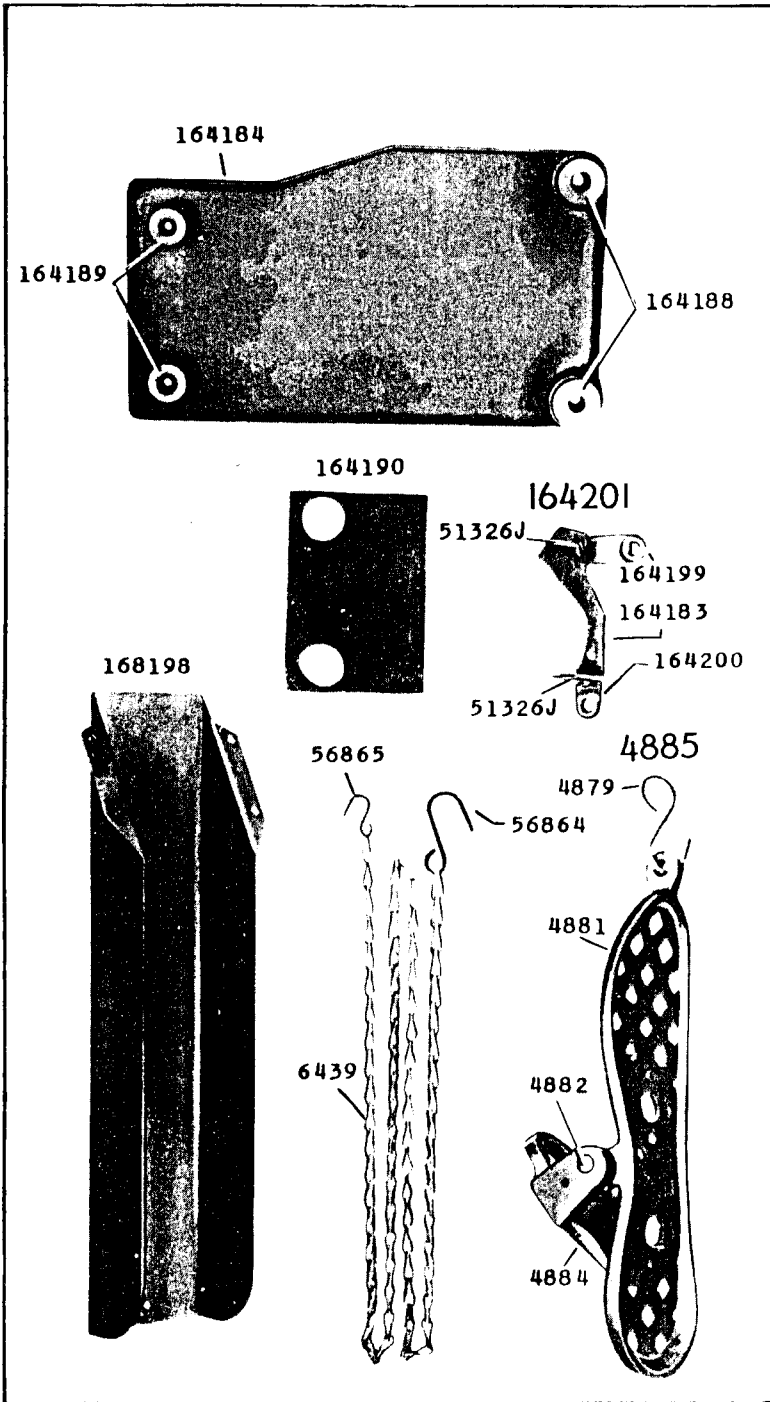



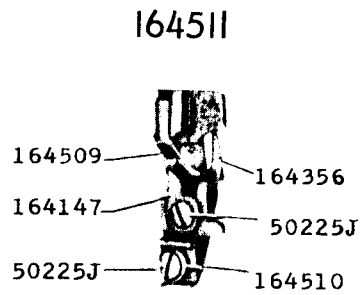
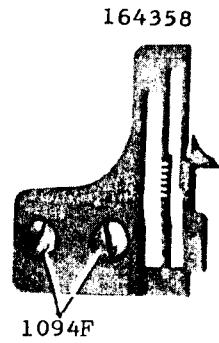
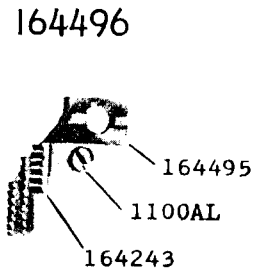
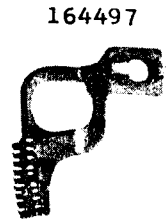

164539

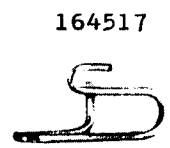
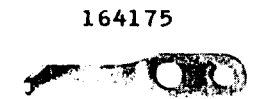
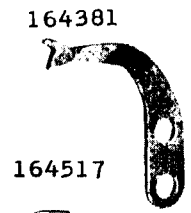
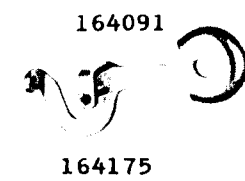
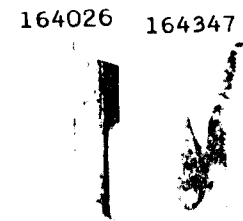
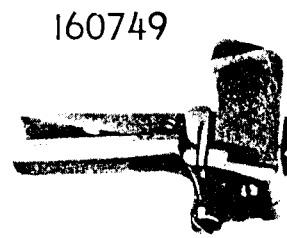
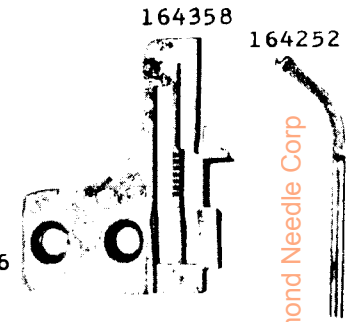
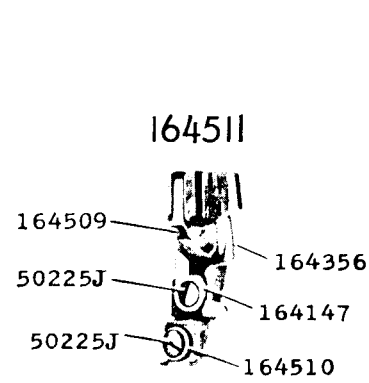
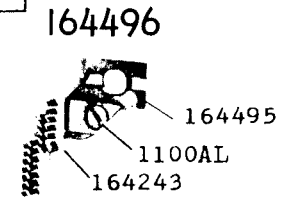

Property of: Diamond Needle Corp

### 164237

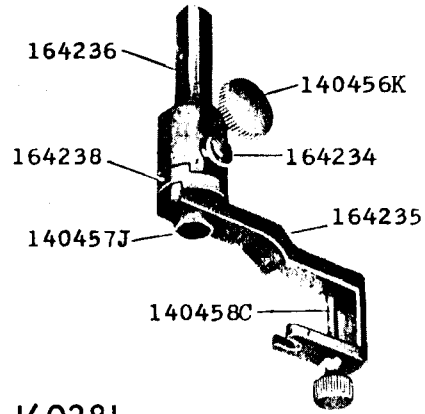

### 160381

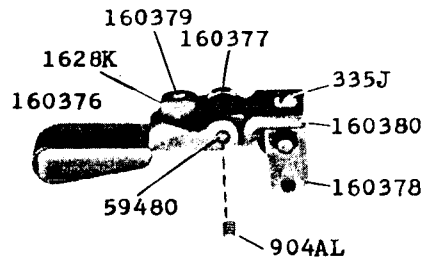

### 160384

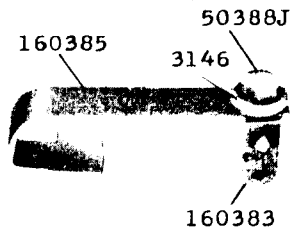

### 160749

